

Specifications

Order No.	543-562A	543-564A	543-561A	543-563A
Measuring range	1.2" (30.4mm)	2.4" (60.9mm)	30.4mm	60.9mm
Resolution	Switchable between .00002" (0.0005mm) and .00005" (0.001mm)		Switchable between 0.0005mm and 0.001mm	
Displacement accuracy (at 20°C)	.00006" (0.0015mm)	.0001" (0.0025mm)	0.0015mm	0.0025mm
Quantizing error	±1 count			
Measuring force	2.0N or less	2.5N or less	2.0N or less	2.5N or less
Measuring orientation	Between vertical (spindle pointing down) and horizontal			
Positional detection method	Photoelectric-type reflection linear encoder			
Maximum response speed	39.37in/sec. (1000mm/sec.)			
Display	7-digit LCD, sign, and analog bar with 2-color backlight			
Contact point	Sphere R=.06" (1.5mm) (cemented carbide)			
Operating temperature range	32°F to 104°F (0°C to 40°C)			
Storage temperature range	14°F to 140°F (-10°C to 60°C)			
Main unit mass	.64 lbs	.67 lbs	290g	305g
Power supply	120V, 50/60Hz AC adapter (6V, 1A)			

Up to 6 digits can be output from the Digimatic port, with truncation from the leading digit if greater than this limit. For example, if the display shows the 7-digit value '123.4565', only '23.4565' would actually be output.

External Dimensions

543-562A

Unit: inch (mm)

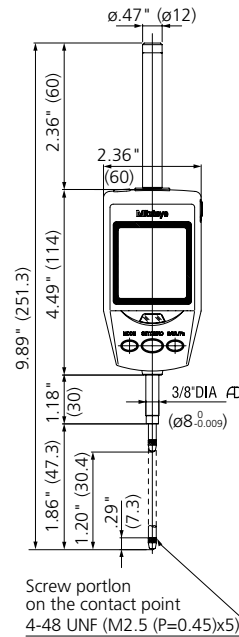

Screw portion on the contact point
4-48 UNF (M2.5 (P=0.45)x5)

543-564A

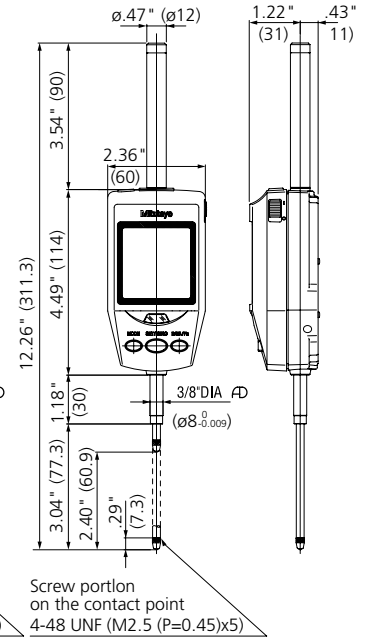

Screw portion on the contact point
4-48 UNF (M2.5 (P=0.45)x5)

Accessories

Standard Accessories

- User's Manual
- Inspection Certificate
- Lifting Lever (Knob)
- AC Adapter

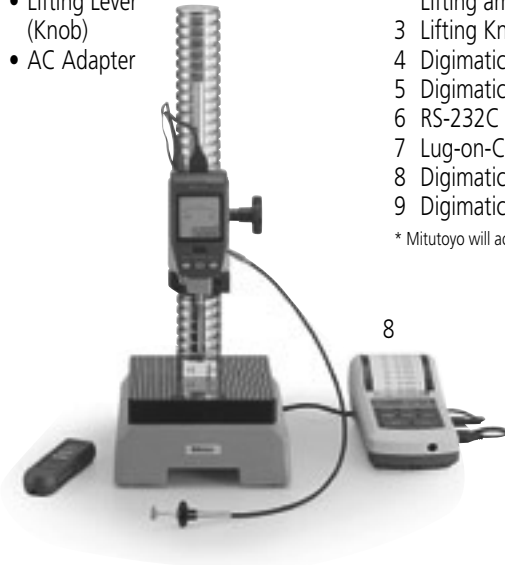

Optional Accessories

- 1 Remote Controller **21EZA099**
- 2 Spindle Lifting Cable
Lifting amount: 1.18" (30mm) **540774**
- 3 Lifting Knob **21EZA101**
- 4 Digimatic Connecting Cable 40" (1m) **936937**
- 5 Digimatic Connecting Cable 80" (2m) **965014**
- 6 RS-232C Connecting Cable 80" (2m) **21EAA131**
- 7 Lug-on-Center Back **101306**
- 8 Digimatic Mini Processor/Printer **264-504-5A**
- 9 Digimatic Presetter **543-003**

* Mitutoyo will accept a special order for an air lifter upon request.



Recommended Stands

(for 543-562A & 543-564A)

- Granite Comparator Stand **517-890**
- Comparator Stand **215-514**
- Comparator Stand **215-831**



215-514